

Instructions and Advices to use the electronic controller Logik 8

ORIGINAL INSTRUCTIONS



INDEX

CAUTIONS	Page 3
TECHNICAL FEATURES	Page 4
MOUNTING	Page 5
ELECTRICAL DRAWING AND LEGEND OF THE CONNECTIONS	Page 5
CONTROL PANEL	Page 7
WORKING PRINCIPLE	Page 7
SETTING THE PARAMETES	Page 7
PARAMETER LIST	Page 8
ALARM CODES	Page 9
MAINTENANCE MESSAGES	Page 9
VISUALIZATION OF THE MAINTENANCE TIMER	Page 10
RESET OF THE MAINTENANCE TIMER	Page 10
VISUALIZATION OF THE WORKING HOURS	Page 10
RESET OF THE WORKING HOUR-METER	Page 10
HOW LOGIK 8 CONTROLS THE COMPRESSOR	Page 11
WARRANTY TERMS	Page 13

CAUTIONS

THE LOGIK 8 IS AN INDUSTRIAL CONTROL EQUIPMENT (NOT A SAFETY INSTRUMENT) FOR THE OPERATION OF A SCREW COMPRESSOR.

THE INSTALLATION MUST BE MADE IN ACCORDANCE TO THE LOCAL AND INTERNATIONAL STANDARDS AND REGULATIONS WHERE THE COMPRESSOR IS MANUFACTURED.

THE INSTALLATION AND START UP OF THE CONTROLLER MUST BE CARRIED OUT BY TRAINED PERSONNEL WELL KNOWN IN THIS MANUAL.

THE CONTROLLER HAS TO BE USED IN STANDARD INDUSTRIAL ENVIRONMENT AND IT CAN NOT BE USED IN EXPLOSION RISK ENVIRONMENT, MARITIME AND MILITARY PURPOSE.

THIS MANUAL COULD BE SUBJECT TO CHANGES; PLEASE CONTACT LOGIKA CONTROL TECHNICAL OFFICE IN CASE OF DOUBT ON THE LAST VERSION.

TECHNICAL FEATURES

- Industrial control equipment for the operation and management of screw compressors only; don't mount and use in explosive room.
 - In accordance to **CE** regulation:
 - Low tension: 2006/95/CE
 - Safety: EN 60730-1 (General regulations)
 - EMC 2004/108/CE
 - In accordance to **UL 508 (FILE #: E316817)**.
 - Inputs and outputs via terminal-block board to wires (300V, 15A, 18-14AWG).
 - Black-grey auto-extinguishing box in ABS:
 - a) **according CE:**
 - IP64 for the front panel and IP20 for the other parts;
 - b) **according UL:**
 - Type 1 and Type 12 for front panel mounting, installation in pollution degree 2 for the other parts.
 - Tightening torque: 7 Nm.
 - Working temperature: -25°C (-13°F) ÷ 50°C (122°F), 90% RH (non condensing).
 - Storage temperature: -30°C (-22°F) ÷ 70°C (158°F).
 - Power supply: 12 Vac ± 10% - 50÷60 Hz (power of transformer's secondary: ~ 6 VA) from safety transformer.
 - Max. current absorbed: ~ 220 mA.
 - Visualization through:
 - nr. 3 green display with 7 segments.
 - nr. 3 green led.
 - nr. 1 input for pressure transducer settable via software into input for electromechanical pressure switch.
 - nr. 1 input for temperature probe to detect air end temperature.
 - nr. 3 key buttons: Start – Stop – Function (visualization of temperature, working hours, maintenance timer and reset).
 - nr 3 opto isolated digital inputs for detection:
 - IN 1 = emergency stop button
 - IN 2 = OR alarm (thermal motor – thermal fan.....)
 - IN 3 = control phase relay or remote start/stop
 - nr. 5 outputs via relay with contact 1.5A max. (general use):
 - RL1 = line contactor
 - RL2 = star contactor
 - RL3 = delta contactor
 - RL4 = load solenoid valve
 - RL5 = settable into alarm or fan contactor
- MAX. RATED CURRENT WITH ALL RELAYS CLOSED: 4.5A**
- Non volatile memory to store setting data, compressor status and working hours.
 - The controller switches OFF due micro interruption of power longer than ~ 300 m.s..

Accessories:

- nr. 1 temperature probe KTY 13.5 with black cable TPE, length 2.5 m, working range -10°C÷130°C, resolution 1°C, precision ± 1°C, to detect air end temperature.
- nr. 1 pressure transducer 4-20 mA for working pressure control: 2 wires, AISI 316L stainless steel membrane, working range 0 ÷ 15 bar, resolution 0,1bar, precision ± 0,1bar.

MOUNTING

Use the drawing below as overall dimensions to mount the controller.

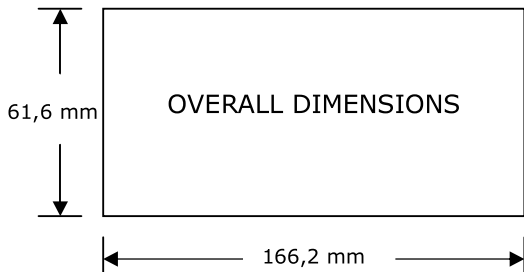

ELECTRICAL DRAWING AND LEGEND OF THE CONNECTIONS

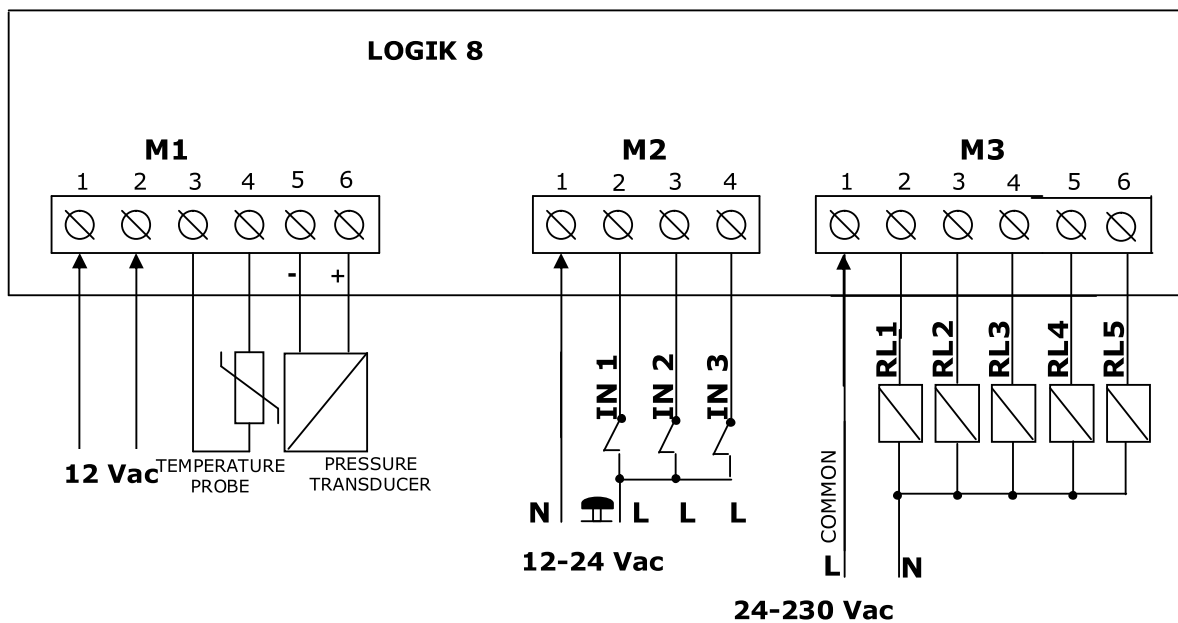

NOTES ON THE CONNECTIONS

Respect the working technical features and instructions on the electrical wiring; in special way both the cables of the temperatures probes and pressure transducers must be isolated from the power cables and proper RC filters must be placed on the contactors' coils.

Besides pay attention low voltage and high voltage cables run on separate trunks.

- On the back side of the controller there must be enough space for wiring and connectors.
- The rear side of the controller must be protected against condensation, oil and dust.
- Don't wash the front panel by water injection; clean the front panel with a soft cloth using soap water.

LEGEND

Terminal M1

Pole 1-2 = power supply 12 Vac \pm 10% 50÷60 Hz

Poles 3-4 = temperature probe

Poles 5-6 = pressure transducer (pole 5 = - negative / pole 6 = + positive) or free contact of the electromechanical pressure switch

Terminal M2

Pole 1 = neutral 0 Vac

Pole 2 = Input IN 1 - pulsante di emergenza  (L)

Pole 3 = Input IN 2 - OR alarms: thermal motor, thermal fan, emergency stop button etc.. (L)

Pole 4 = Input IN 3 - control phase relay (L)

Terminal M3

Pole 1 = common relay 24-230 Vac

Pole 2 = output relay RL1 - line contactor

Pole 3 = output relay RL2 - star contactor

Pole 4 = output relay RL3 - delta contactor

Pole 5 = output relay RL4 - load solenoid valve

Pole 6 = output relay RL5 - alarm or fan contactor

EXAMPLE OF CONNECTION TO THE SECURITY PRESSURE SWITCH

Contactors 24 Vac

If the operation of the contactors and solenoid valves come through 24 Vac, the digital inputs have to be connected to 24 Vac (see drawing on the right); on this way when the pressure switch opens due to high pressure, 24 Vac lacks and deenergize all the contactors, solenoid valve and digital: the controller detects all the digital inputs opened and signal the alarm "AL9".

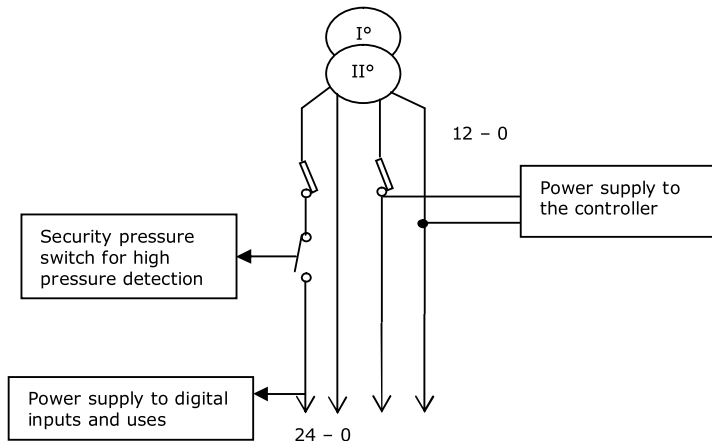

Contactors 230 Vac

If the operation of the contactors and solenoid valves comes through 230 Vac, the digital inputs have to be connected to 12 Vac; next to the contact of the pressure switch, place and energize an auxiliary relay and put the contact in serie to 12 Vac (L) (see drawing on the right).

When the pressure switch is closed, the auxiliary relay with contact closed supply power to the digital inputs; the power supply of the controller is connected before the contact of the relay.

When the pressure switch opens, the auxiliary relay opens power to the digital inputs; the controller detects all the digital inputs opened and signal the alarm "AL9".

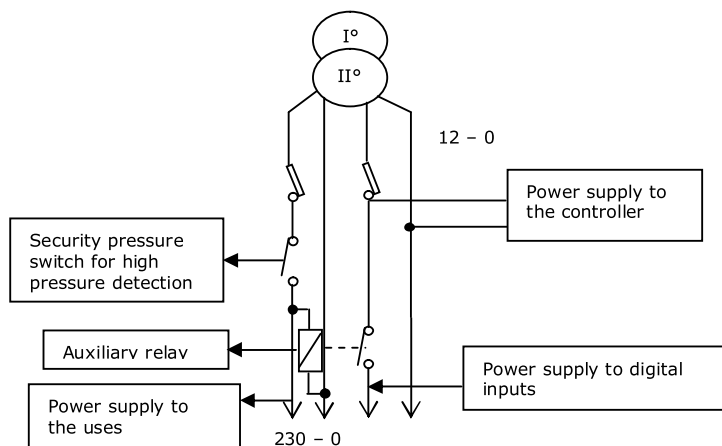

CONTROL PANEL

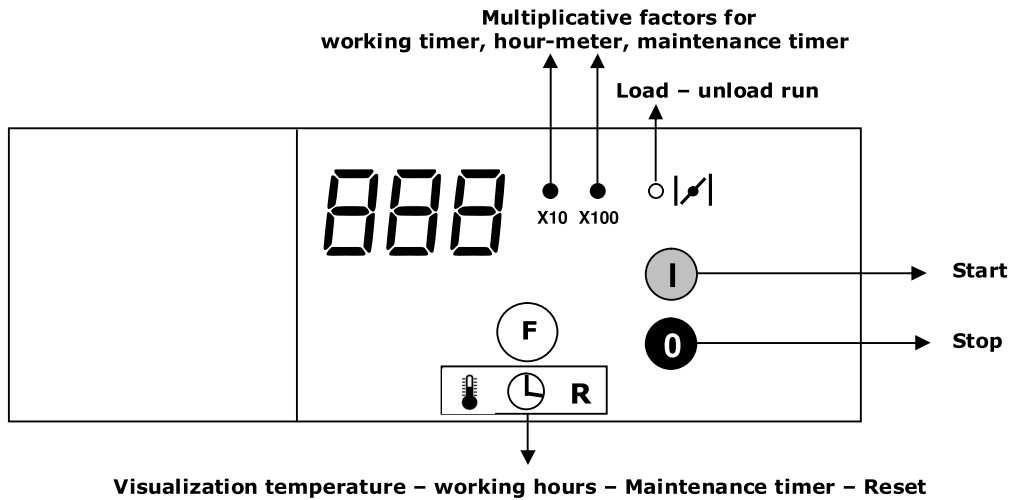

WORKING PRINCIPLE

- 1) Supplying power to the compressor, the display visualizes the message **OFF**.
- 2) In OFF status, the compressor starts by pushing the button **I** and the display visualizes the working pressure or working temperature (according the setting of the parameter P01 = pressure control via pressure transducer or electromechanical pressure switch)
- 3) The compressor stops by pushing the button **O**.
- 4) In case of alarm detected, the display visualizes the pertinent alarm code.

SETTING THE PARAMETERS

When the compressor is OFF by pushing at the same time **F** and **O** for 3 seconds enter into the setting of the parameters and the display visualizes the code of the parameter; pushing the button **F** the display visualizes the set value and by **I** and/or **O** change the value; pushing **F** again, visualize the code of the parameter and by the buttons **I** and/or **O** flow up/down the codes of the next parameters; to enable the setting of the parameters, always push the button **F** as explained above.

Quit the setting by pushing the button **F** for 3 seconds e comes back to OFF.

During the setting, if the value to set is equal to the higher or lower value of the settable range, the value visualized starts blinking on the display.

ANTIPANIC FUNCTION

For safety reasons, during the setting if no one button is pushed for 60 seconds from the last pushing of any button, the controller quit the setting automatically saving the values changed.

PARAMETERS LIST

Function	Description	Settable values	Default
P01	Pressure control	0 (transducer) ÷ 1 (pressure switch)	0
P02	Top range pressure transducer	15 ÷ 16	15 bar
P03	High pressure alarm	(P02-0,5) ÷ (P04+0,5)	11 bar
P04	Stop pressure	(P03-0,5) ÷ (P05+0,2)	10 bar
P05	Start pressure	(P04-0,2) ÷ 3	8.5 bar
P06	Offset pressure transducer	-2,0 ÷ +2,0	0
P07	Max. range air end temperature	130°C ÷ (P07+2 C°)	130°C
P08	High air end temperature alarm	(P07-2°C) ÷ (P09+2°C)	110°C
P09	High air end temperature warning	(P08-2°C) ÷ (P10+2°C)	105°C
P10	Low air end temperature alarm	(P09-2°C) ÷ -10°C	0°C
P11	Temperature probe offset	10 ÷ +10°C	0°C
P12	Star/delta timer	2 ÷ 20 sec.	5 s
P13	Star timer	10 ÷ 50 m.s.	20 ms
P14	Timer before starting to load	1 ÷ 5 sec.	2 s
P15	Unload time	0 ÷ 10 min.	2 min
P16	Timer P15 variable	0 (fisso) ÷ 1 (variabile)	0
P17	Safety timer	1 ÷ 240 sec.	30s
P18	Change air filter	100 ÷ 3.000 h	2.000 h
P19	Change oil filter	100 ÷ 9.900 h	2.000 h
P20	Change separator filter	100 ÷ 9.900 h	4.000 h
P21	Change oil	100 ÷ 9.900 h	4.000 h
P22	Check compressor	100 ÷ 9.900 h	500 h
P23	Starts/hour	0 ÷ 60	0
P24	Low voltage alarm	0 ÷ 1	1
P25	Remote start/stop IN3	0 ÷ 1	0
P26	Scale detection pressure	0 ÷ 1	0
P27	Scale detection temperature	0 ÷ 1	0
P28	RL5 set	0 ÷ 1	0
P29	Fan ON (RL5)	(P09-2°C) ÷ 30°C	70°C
P30	Delta T fan OFF (RL5)	5 ÷ 15°C	10°C
P31	Security*	0 / 1	0

NOTES ON THE PARAMETERS:

- 1) In case of setting parameter P01 = **1**, the parameters P02 ÷ P06 will not be visualized.
 - 2) Selecting the parameter P24= **0**, if the power supply to the controller goes down 9.0 Vac, the controller switches off and restart automatically (with a delay time set on parameter P17) when the power overcomes 10.5 Vac: the display doesn't visualize any alarm for low voltage.
Selecting the parameter P24 = **1**, if the power supply to the controller goes down 9.0 Vac, the controller switches off; when the power overcomes 10.5 Vac, the controller visualizes the alarm code **AL7** standing in OFF status.
 - 3) P25 = 0 input IN3 enabled as control phase relay and joined to related alarms wrong/missing phase.
P25 = 1 input IN3 enabled as remote start/stop (control phase relay disabled).
 - 4) Selecting the parameter P28 = **0**, RL5 operates as alarm relay and the parameters P29 and P30 are not visualized.
Selecting the parameter P28 = **1**, RL5 operates the fan contactor and the parameters P29 and P30 are visualized.
 - 5) The counting of the parameters P18 ÷ P22 is pertinent to ON time of RL1 and comes to backwards: when the counting reaches 0, goes on as negative counting.
The storage of the hours comes every 15 minutes; if power lacks during this time, the split of 15 minutes time is missed.
 - 6) If the parameter P22 is set 9.900 will not generate the pertinent alarm
 - 7) The parameter P23 is the max. starts per hour allowed to the motor (see alarm code **AL8**). If you set it "0" the starts/hour control is not operated.
 - 8) The parameter P26 allows to detect and visualize the pressure in two different scales:
0 = bar - 1 = PSI.
 - 9) The parameter P27 allows to detect and visualize the temperature in two different scales:
0 = °C (Celsius) - °F (Fahrenheit)
- ***P31** = Security is related to the timer CAF (change air filter): once CAF timer is over, the compressor shut-off and the display visualizes the alarm code A13.

Setting: when you enter into the selection of the parameters, by pushing ON and OFF buttons at the same time for 3 seconds the editing of P31 is enabled. Default = 0 (disabled)

ALARM CODES

WARNINGS (VISUAL ALARMS)

AL0 = setting data lost; default values restored (the alarm code blinks on the display).

AL4 = high air end temperature warning: the value detected by the temperature probe over set P09 (alarm code alternated by the visualization of the pressure or temperature according the set of the parameter P01: automatic reset when the temperature goes down set – 2°C).

AL8 = inform the compressor will never stop till the expiration of 1 hour time from the first start; it will run load/unload according the pressure.

NOTE: in case of warning, RL5 (set "0") is intermittently energized.

ALARM MESSAGES WITH IMMEDIATE COMPRESSOR SHUT OFF

AL1 = phase inverted/missing phase: IN3 (control phase relay) changes to N.O. (Normally Open).

AL2 = IN 2 (OR alarms) changes to N.O. (Normally Open).

AL3 = high air end temperature: temperature detected by the probe over set P08.

AL5 = air end temperature probe failure.

AL6 = low air end temperature: temperature detected by the probe below set P04.

AL7 = low voltage.

AL9 = security pressure switch opened: missing power supply to all the digital inputs.

*A10 = pressure over set P03 (alarm detected if parameter P01 = 0).

*A11 = pressure transducer failure (possible wrong setting of the parameter P01: pressure transducer – pressure switch or pressure transducer failure)

*A12 = emergency stop button opened

*A13 = Security (Parameter P31 set as "1"): reset CAF timer to enable alarm resetting.

NOTE: when the compressor shuts off, all the relays are de-energized and RL5 (P25 = 0) is energized.

*** Having only 3 characters available on the display the alarms AL10, AL11, AL12 and AL13 will be short cut as A10, A11, A12, A13.**

MAINTENANCE MESSAGES

F-A = change air filter (timer P18 elapsed)

F-O = change oil filter (timer P19 elapsed)

F-S = change separator filter (timer P20 elapsed)

OIL = change oil (timer P21 elapsed)

C-h = check compressor (timer P22 elapsed)

It's possible to reset the shut off alarms by pushing the button **F** only when the compressor is OFF.

It's possible to reset the warnings (visual alarms) and maintenance messages by pushing the button **F** even if the compressor is in operation.

NOTES:

- 1) The shut off alarms have priority on the warnings (visual alarms) while the warnings have priority on the maintenance messages.
- 2) If a maintenance message is visualized and then reset by the button **F** but the pertinent timer is not reset, the next power on this maintenance message will be visualized on the display again.
- 3) The alarm codes and maintenance codes are visualized in every compressor status.

VISUALIZATION OF THE TEMPERATURE

In case of parameter P01 = **1** (electromechanical pressure switch) the temperature is visualized on the display directly, during the operation.

In case of parameter P01 = **0** (pressure transducer), when the compressor is ON, to visualize the temperature, push easily the button **(F)**; after 5 seconds the temperature is visualized, the display shifts back to visualize the working pressure again.

VISUALIZATION OF THE MAINTENANCE TIMER

When the compressor is ON, to visualize the maintenance time:

push **(F)** and the display visualizes the message **F-A** (Air Filter); pushing it again, the display visualizes the residual hours of the pertinent timer; going on pushing **(F)** the display visualizes the message **F-O** (Oil Filter), the message **F-S** (Separator filter); the message **OIL** (Oil), the message **C-h** (Check compressor) with the residual hours of the pertinent timer.

Visualizing the residual hours of the parameter **C-h**, pushing **(F)**, the display shifts back to the main visualization.

NOTE:

- 1) if within 60 seconds the button **(F)** is not pushed, the controller shifts back to the main visualization.
- 2) if the timer is negative, the first digit on the display visualizes the symbol “-” while the other digits the hours; in case of hours more than 99 the pertinent led of multiplicative factors is lighted

RESET OF THE MAINTENANCE TIMER

The reset is operated when the compressor is OFF only.

Pushing the button **(F)** for 3 seconds, the display visualizes the message **F-A** (Air filter); pushing it again the residual hours (blinking) of the pertinent timer; to operate the reset push **(F)** for 3 seconds and after that the display shifts to the next message **F-O** (Oil filter); if you don't need to reset this timer, easily push the button **(F)** to shifts to the next timer **F-O** (Oil filter).

As per timer **F-A**, going on pushing **(F)** the display visualizes the timer **F-S** (Separator filter), **OIL** (Olio), **C-h** (Check compressor) with the pertinent residual hours (blinking); to reset these timer follow the same procedure as per timer **F-A**.

After the reset of the last timer **C-h** the display shifts to the message **OFF**.

NOTE:

if within 60 seconds the button **(F)** is not pushed, the controller shifts back to the main visualization.

VISUALIZATION OF THE WORKING HOURS

When compressor is ON, to visualize the working hours:

push at the same time the buttons **F** and **I** for 3 seconds and the display visualizes the message **h-t** (counting of ON hours of RL1); pushing **F** again the display visualizes the pertinent hours, lighting the led for multiplicative factor, just in case.

Pushing **F** again, the display visualizes the message **h-L** (counting of ON hours of RL4); pushing it again the display visualizes the pertinent hours, lighting the led for multiplicative factor, just in case.

Pushing **F** again, the display visualizes the message **n--** (counting of starts/hour); pushing **F** again, the display visualizes the number of starts/hours.

Pushing **F** again, the display visualizes the message **rEL** (software release); pushing **F** again, the display visualizes software release loaded in the controller. Pushing **F** again, the display shifts back to main visualization.

RESET OF THE WORKING HOUR-METER

To reset hour-meter the compressor must be absolutely in OFF.

Pushing **0** **I** **F** for 3 seconds (at the same time), the display visualizes the message **r-h**; push **F** for 3 seconds to start the reset and after that the message **r-h** will start blinking: reset of total working hours and load hours is in progress. Once the reset is over, the display visualizes the message **OFF**.

HOW LOGIK 8 CONTROLS THE COMPRESSOR

1) Power on:

- a) the display visualizes the message **OFF**;
- b) all the relays are OFF (de-energized).

2) Compressor ON by pushing **I**: the display visualizes the temperature and led  indicates the status of RL4 (load solenoid valve).

Safety time P17

Pushing the stop button **0**, the compressor stops according the following procedure:

- a) if the compressor is loading, changes to unload run for the time set on P17; during this time the restart is accepted through the start button **I**; once the timer P17 is elapsed, the compressor stops and the display visualizes the message "**OFF**";
- b) if the compressor is running unload and P15 in progress is higher than P17, once P15 is elapsed the compressor stops and the display visualizes the message "**OFF**"; if P15 in progress is lower than the set on P17, P17 starts; once P17 is elapsed the compressor stops and the display visualizes the message "**OFF**";
- c) if the compressor is OFF due to pressure set reached, it stops and the display visualizes the message "**OFF**";
- d) when the compressor stops and the display visualizes the message "OFF", the timer P17 starts; during the timer if the start button **I** is pushed, the message "ON" starts blinking alternate to the value of pressure or temperature detected (according the selection of the parameter P01) and the compressor doesn't start; the compressor will start when the timer P17 elapses.

In case the compressor stops due to any alarm, the timer P17 starts; during this time if the message is reset and the start button **I** is pushed, the message "ON" starts blinking alternate to the value of pressure or temperature detected (according the selection of the parameter P01) and the compressor will start when the timer P17 elapses.

Operation of remote start/stop on IN3

If remote start/stop on input IN3 is enabled (setting P25 = 1), when the compressor is ON by **I** if the input IN3 opens, the display visualizes the message "**StP**" and the compressor will start running unload according the same functions as per pushing stop button **0**; while the compressor shift from load to unload running by remote start(stop, the display visualizes the message "**StP**" alternating the pressure or temperature detected (depending on setting of parameter P01 = pressure control).

Operation of the load solenoid valve (RL4)

1) **P15** set as fixed time = 0

When the pressure reaches the stop set, RL4 switches **OFF**, the display visualizes the pressure and/or temperature (according pressure control set in the parameter P01) and the timer P15 starts; when P15 is elapsed if the pressure is still over the start set, the compressor stops; during P15 in progress, if the pressure goes down the start set, the load solenoid valve RL4 switches **ON** and the display visualizes the pressure and/or the temperature while P15 erases.

2) **P15** set as variable time = 1

On the first start the compressor works as explained to point 1 above; on the next load run, the controller counts the time the pressure spend to decrease from stop to start set; if this time (**tx**) is higher than the set on P15, the next unload run, P15 will be reduced of 1 minute and so on up to a minimum time of 2 minutes.

The first cycle **tx** comes to be lower than P15 changed, the next unload run will come back to be counted as the value set on P15.

Fan operation (RL5 = 1)

When the delta contactor (RL2) is energized, the fan contactor (RL5) is operated according the following procedure:

- a) if the air end temperature is equal or higher than set on P26 = RL5 ON;
- b) if the air end temperature is lower than set on (P26 - P27) = RL5 OFF.

WARRANTY TERMS

24 (twenty-four) months from the production date printed on the label of the serial number.

Temperature probe is not included in the warranty terms.

Both working and technical features of the controller must be fully respected: the warranty declines if the controller has been tampered or repaired by unauthorized personnel.

Operation or modification different from the original, wrong electrical wiring or bad assembling can be cause of failures or malfunctioning of the controller; in these cases both warranty and own technical features of the controller declines.

Technical features, drawings and any other document in this manual are property of Logika Control that forbid any reproduction, even partial, of text and illustrations.

On its unquestionable judgement, Logika Control reserves the authority to modify the product to improve operation and performance, besides to the right to withdraw the product from the production, in any time and without notice.

REVISION INDEX

Revision 0 = Issue

Revision 0.1 = Issue for UL certification

Revision 0.2 = Modification on parameter P25: IN3 configuration as control phase relay or remote start/stop resulting in slippage of the following codes; upgrade of software release in menu "Working hours" and top range starts/hour from 20 to 60.

Revision 0.3 = Addition parameters: P26 and P27 respectively as selection pressure bar/PSI and temperature scale °C (Celsius)/°F (Fahrenheit) – firmware release 0.16

Revision 0.4 = Addition parameter P31 Security – release firmware 0.19

Revision 0.5 = Revision edit of parameters

LOGIKA CONTROL s.r.l.
Via Garibaldi, 83/a
20054 NOVA MILANESE – MI –
ITALY
Tel.: +39 0362 37001
Fax: +39 0362 370030
Web: www.logikacontrol.it