

DIAGRAMMI DI FLUSSO - SYSTEM DIAGRAMS - FLUSSDIAGRAMM

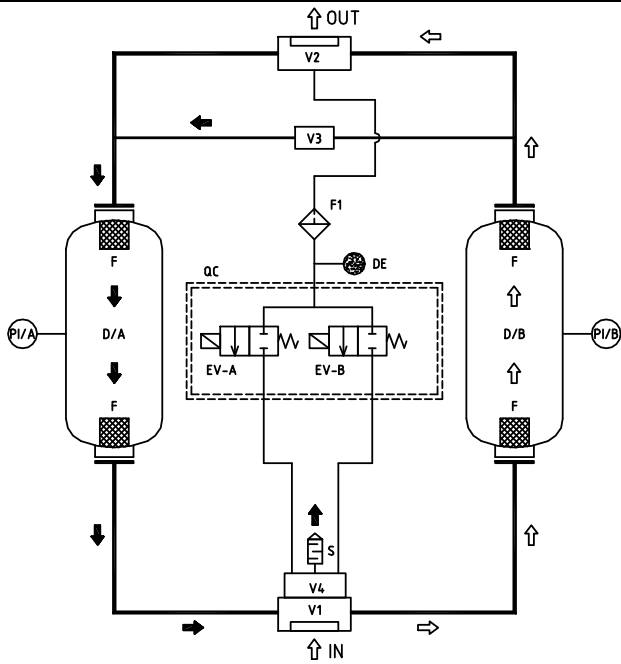

Mod. 40 - 200 Nmc/h
Mod. 25 - 125 cfm

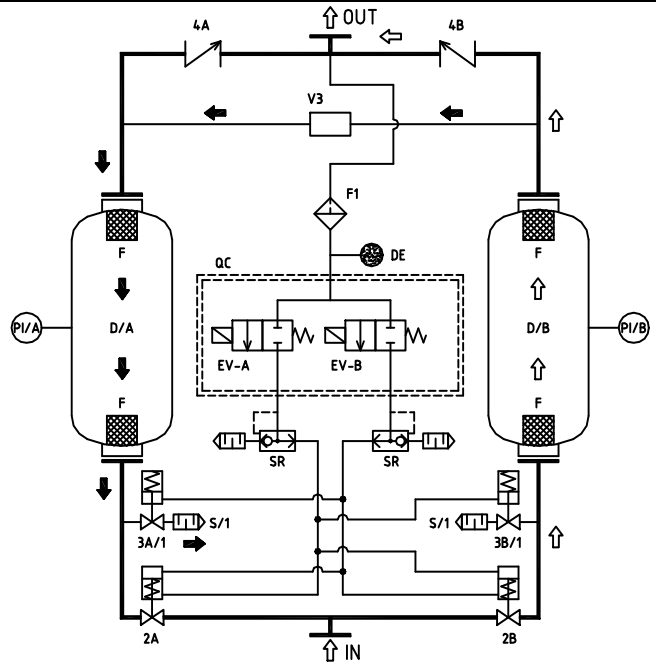

Mod. 400 - 480 Nmc/h
Mod. 250 - 300 cfm

← IN RIGENERAZIONE
← REGENERATION

← IN ESERCIZIO
← OPERATING

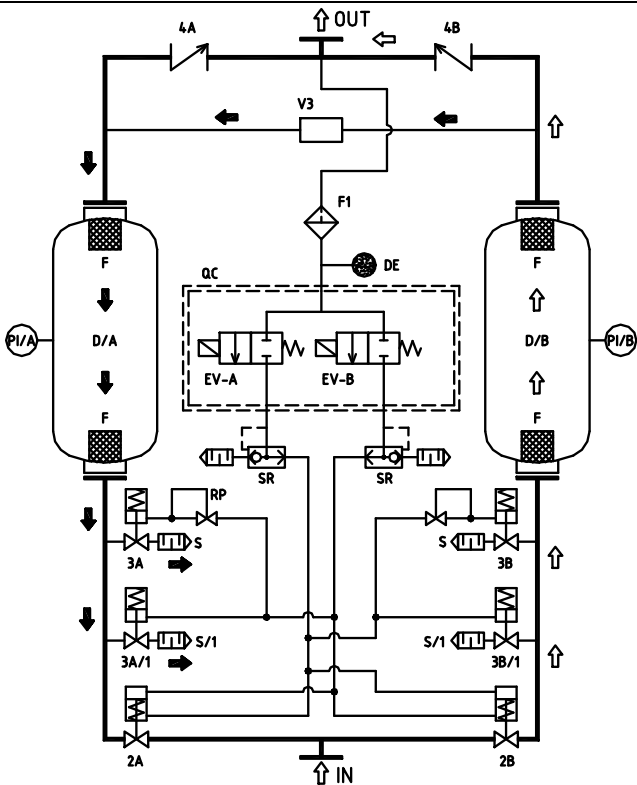

Mod. 750 - 900 Nmc/h
Mod. 450 - 550 cfm

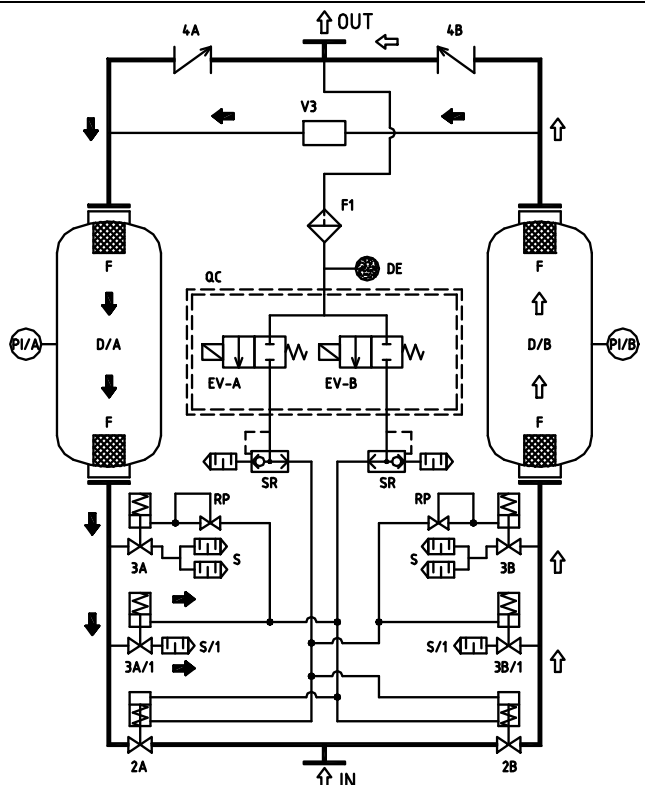

Mod. 1200 - 1800 Nmc/h
Mod. 720 - 1050 cfm

D/A D/B ADSORBER VESSEL
F INTERNAL FILTERS
V1 INLET VALVE
V3 PURGING DEVICE
V4 DECOMPRESSION VALVE
F1 SINTERED FILTER
DE EFFICIENCY INDICATOR
RP PRESSURE REGULATOR

S - S1 SILENCER
2A 2B INLET PNEUMATIC VALVES
3A 3B PRE DECOMPRESSION VALVES
PCV PRESSURE REDUCING
EV-A/EV-B PILOT ELECTROVALVES
PI/A PI/B MANOMETERS
SR AIR DISCHARGE
QC COMMAND PANEL