

Indice	Date révision	Auteur	Nature de la révision	Visa Responsable

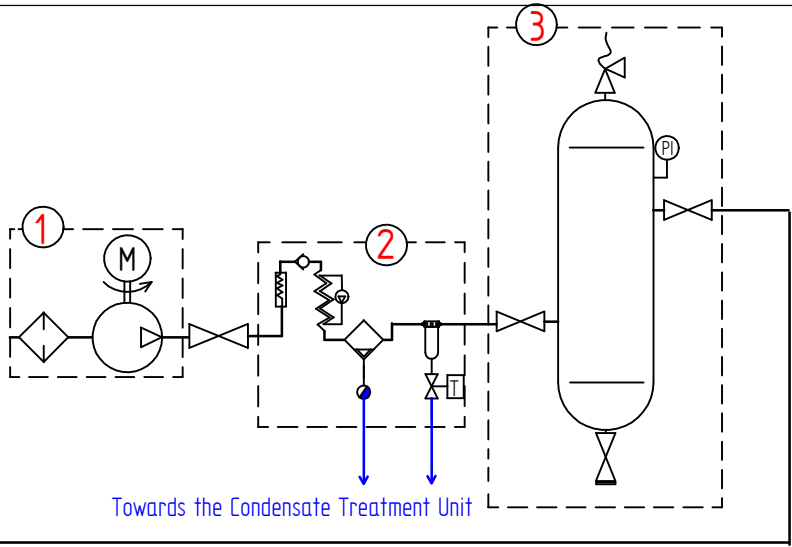

1	Air Compressor
2	Dryer
3	Compressed Air Tank
4	Air Filters
5	Premium Plus Generator
6	Oxygen Tank (6 bar, 95% purity)
7	Oxygen Tank (1 bar, 99% purity)
8	Booster and Booster's Tank
9	Oxygen Tank (end receiver)
10	Oxygen Filter

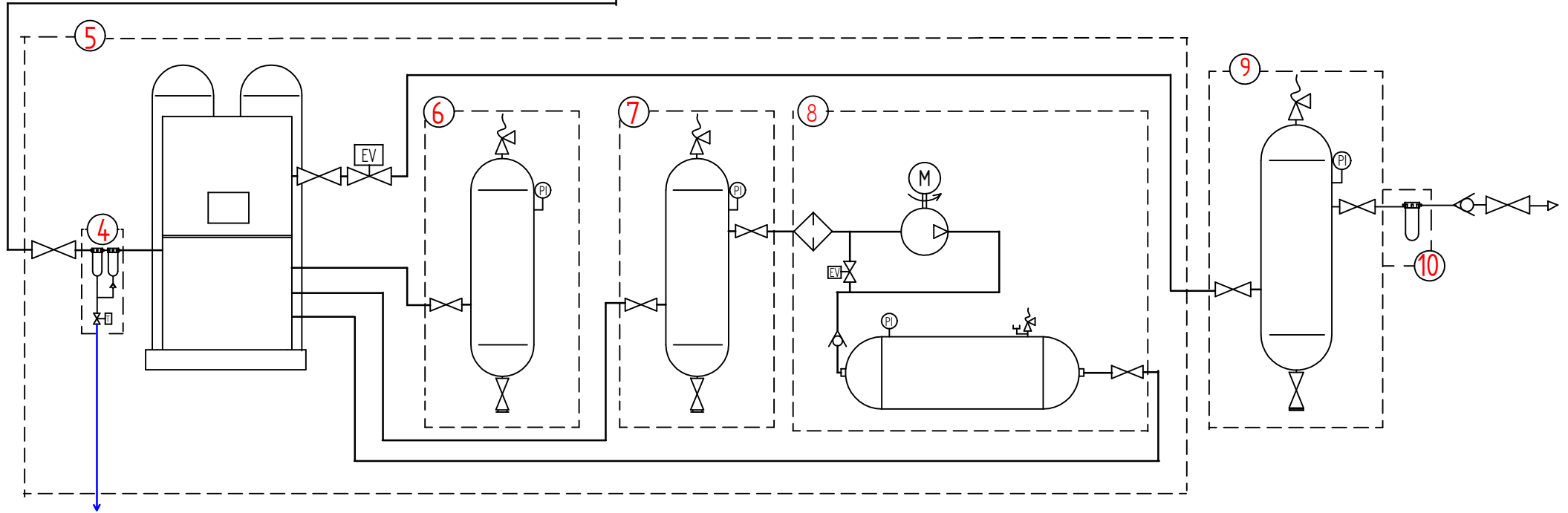

Ech :	Matière :	Poids :		Dessiné Le 29/12/2016	Par : D NISTOR
				Visa Responsable :	

<p>Typical Installation Diagram for Premium Plus Oxygen Generator</p> <p><small>Ce document est la propriété de NOVAIR. Il ne peut être reproduit et/ou communiqué sans autorisation. This document belongs to NOVAIR. It cannot be reproduced and/or transmitted without authorization.</small></p>			 6, Rue Paul Langevin 93274 SEVRAN Cedex - FRANCE Tél : 01 43 84 94 83 - Fax : 01 43 84 87 40 www.novair.fr	<table border="1"> <thead> <tr><th colspan="2">Indice</th></tr> </thead> <tbody> <tr><td>A</td><td> </td></tr> <tr><td> </td><td> </td></tr> <tr><td> </td><td> </td></tr> <tr><td> </td><td> </td></tr> <tr><td> </td><td> </td></tr> </tbody> </table>	Indice		A									
Indice																
A																
PLANCHE : 1 / 2	PLAN N° : PR 069 3 001	CODE ARTICLE :														

REF: NOVAIR-LEPONS-ASHT-E-003925

Indice	Date révision	Auteur	Nature de la révision	Visa Responsable

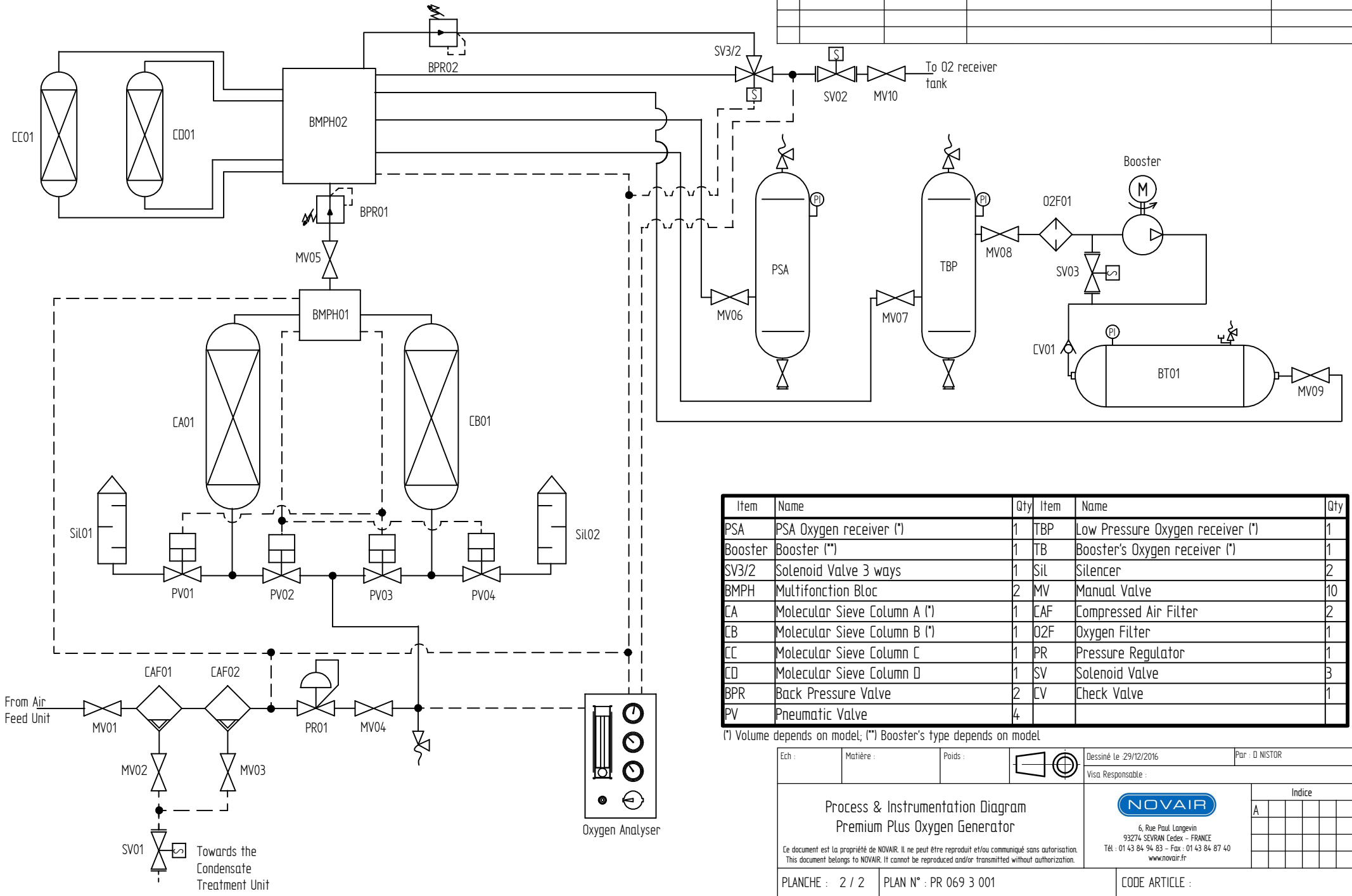

Item	Name	Qty	Item	Name	Qty
PSA	PSA Oxygen receiver (*)	1	TBP	Low Pressure Oxygen receiver (*)	1
Booster	Booster (**)	1	TB	Booster's Oxygen receiver (*)	1
SV3/2	Solenoid Valve 3 ways	1	Sil	Silencer	2
BMPH	Multifonction Bloc	2	MV	Manual Valve	10
CA	Molecular Sieve Column A (*)	1	CAF	Compressed Air Filter	2
CB	Molecular Sieve Column B (*)	1	O2F	Oxygen Filter	1
CC	Molecular Sieve Column C	1	PR	Pressure Regulator	1
CD	Molecular Sieve Column D	1	SV	Solenoid Valve	3
BPR	Back Pressure Valve	2	CV	Check Valve	1
PV	Pneumatic Valve	4			

(*) Volume depends on model; (**) Booster's type depends on model

Ech :	Matière :	Poids :		Dessiné Le 29/12/2016	Par : D NISTOR
<p align="center">Process & Instrumentation Diagram Premium Plus Oxygen Generator</p>				<p align="center">NOVAIR</p> <p align="center">6, Rue Paul Langevin 93274 SEVRAN Cedex - FRANCE Tél : 01 43 84 94 83 - Fax : 01 43 84 87 40 www.novair.fr</p>	
<p>PLANCHE : 2 / 2</p>		<p>PLAN N° : PR 069 3 001</p>		<p>CODE ARTICLE :</p>	

CE DOCUMENT EST LA PROPRIÉTÉ DE NOVAIR. IL NE PEUT ÊTRE REPRODUIT ET/OU COMMUNIQUÉ SANS AUTORISATION.
THIS DOCUMENT BELONGS TO NOVAIR. IT CANNOT BE REPRODUCED AND/OR TRANSMITTED WITHOUT AUTHORIZATION.

Ech: 1/1000 - 2016.12.29